

AMERICAN RANGE

PROFESSIONAL QUALITY COOKING EQUIPMENT

PERFORMER SERIES
30" Range with Open Gas Burners



ARROB-430

(shown with optional 4" stub back and leg caps)

DESIGN



CLASS



FUNCTION

DESIGNED & BUILT IN USA
PROFESSIONAL COOKING EQUIPMENT

30" RESIDENTIAL GAS RANGE

RANGE TOP FEATURES

- True commercial lift-off burners for easy cleaning
- 3 sizes of burners to serve your everyday needs: 22,000 BTU (lg), 18,000 BTU (med) and 12,000 BTU (sm)
- Variable infinite flame settings for all open top burners
- Fail-safe system ensures re-ignition in the event the flame goes out
- Continuous and flush commercial-grade cast iron grates
- Porcelainized burner pans catch spills and lift out for easy cleaning
- Analog controls provide easy, push and turn operation ensuring child safety
- Blue LED light indicates oven functions
- Heavy duty metal die-cast black satin knobs with chrome bezels
- Stainless Steel Island Back Trim included and installed
- Front panel switch controls oven lighting for optimal visibility
- One piece durable precision frame construction oven front

OVEN FEATURES

- Multiple functions include: Standard Bake, Innovention® Convection Bake, Infrared Broil and Fan mode
- Innovention® System with convection fan optimizes uniform air flow
- Two chrome plated heavy duty racks with 4 (including base) positions on heavy chrome side supports
- Accommodates full size commercial sheet pan
- Ceramic Infrared Broiler provides rapid searing at 1,800°F
- Quick Preheat times & uniform cooking temp. with 28,000 BTU Bake Burner
- Extra-large viewing window in oven door
- Porcelainized oven interior simplifies cleaning

INNOVECTION® CONVECTION OVEN TECHNOLOGY

Balanced turbulent heat distribution is essential when baking, roasting, and dehydrating food. The American Range Innovention® convection oven technology features dual convection motors and louvered side panels to enhance uniform heat distribution throughout the large oven cavity. The strategic placement of the dual Innovention® convection fans ensures consistent heat distribution even when challenged with cooking the largest turkey, ham or roast.



INNOVECTION® CONVECTION OVEN IS GREEN TECHNOLOGY

The highly efficient design of the Innovention® Convection Oven uses 19% less gas versus a standard convection oven.

TECHNICAL SPECIFICATIONS

Overall Oven Capacity	4.3 CU. FT.
Oven Dimensions	26" W x 19" D x 15" H
Surface Burner Rating	22,000 BTU (lg) - 18,000 BTU (md) - 12,000 BTU (sm)
Infrared Broiler	17,000 BTU
Oven Bake Burner	28,000 BTU
Total Gas Connection Rating	ARROB-430 119,000 BTU 4 burners
Gas Supply	7" W.C. Natural, 11" W.C. Propane
Electrical Supply	120 VAC 15 AMP 60 Hz Single Phase
Shipping Weight	335 Lbs

COLOR KNOBS

red knobs fits: ARR-430	KSR-GF430
burgundy knobs fits: ARR-430	KSB-GF430

ACCESSORIES & OPTIONS

Island Back (standard) ARR-30SIB-P	20" High Back w/ Shelf ARR-302IHBS-P	Set of 2 Casters ARR-2CAS-P	Porcelainized Broiler Pan R31005
Island Back (welded) ARR-30IB-P	S/S Curb Base ARR-30CB-P	12" Cutting Board ARR-CUTB-12-P	Wok Adapter ARR-WOK-P
4" Stub Back ARR-304SB-P	S/S Leg Caps (2) ARR-2LC-P	12" Griddle Plate ARR-PGPI2-P	

CUSTOMIZE YOUR RANGE: Now you can customize your American Range to match your kitchen setting. Pick from numerous colors and finishes to give your range a unique one-of-a-kind look. For more details regarding color and finish options, go to our website: www.americanrange.com.

DESIGNER COLORS



DESIGNER FINISHES



N = Natural gas Must ship from factory with proper gas type.
L = LP Gas Must provide **N** or **L** after model number for type of gas needed.
Example: ARR-304
 Must specify elevation if over 1000 ft. when ordering.

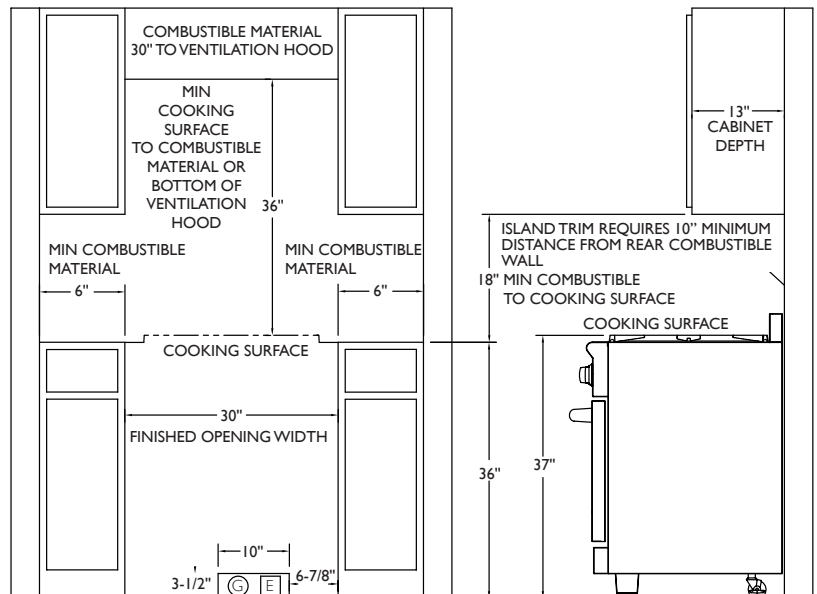
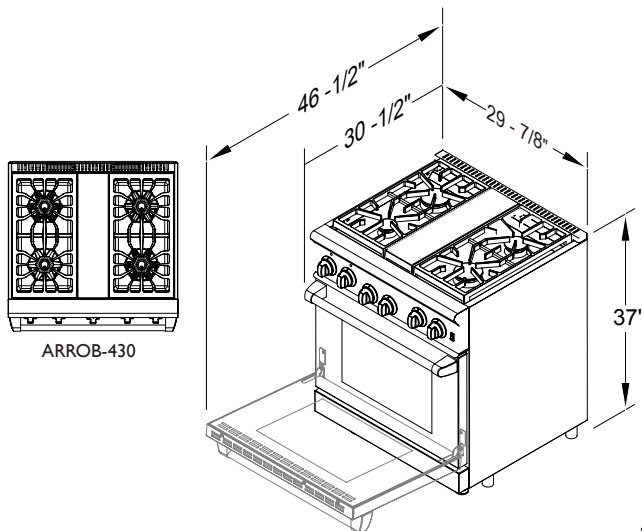

ISLAND OR PENINSULA INSTALLATIONS 10" MINIMUM CLEARANCE FROM BACK OF RANGE TO COMBUSTIBLE SURFACE ISLAND TRIM IS 0". CLEARANCE TO NON COMBUSTIBLE SURFACE NO SIDE WALL ABOVE COOKING SURFACE (G) (E) LOCATION OF GAS AND ELECTRICAL SUPPLY