



Kelvinator
 250 Bobby Jones Expressway | Augusta, GA 30907
 Customer Service: (706) 651-1751 | (866) 738-1640
 Parts Department: (800) 599-7569
 www.kelvinator.com

MODELS

COMMERCIAL FREEZER
 BOTTOM MOUNT REACH-IN



KFS220RGW
 21.8 Cu. Ft. Gross Capacity
 Left-hand door swing only.

KFS221LGW
 21.8 Cu. Ft. Gross Capacity
 Right-hand door swing only.

KFS220RGW
KFS221LGW
 INTERIOR | EXTERIOR
KEY FEATURES

- NSF-certified for food service applications.
- Stainless steel door with lock, white cabinet.
- Stainless steel handle.
- Heavy-duty, locking casters.
- Heavy-duty cooling system, meets NSF / ANSI 7 standards.
- Dynamic condenser improves performance in higher temperature environments.
- 3 heavy-duty steel shelves.
- Stainless steel evaporator cover.
- NSF-certified temperature gauge.
- Interior lighting system.
- Commercial ENERGY STAR® qualified.
- Left and right hand door swing available.

Manufactured by
 Electrolux Home Products

WARRANTY

Kelvinator Commercial products are covered by a one year limited warranty. Refer to the Use and Care manual for details.

Item #:

Project:

Location:

Date: Quantity:



USA
 Electrolux Major Appliances, North America
 250 Bobby Jones Expressway, Augusta, GA 30907
 1-866-738-1640 | www.kelvinator.com

CANADA
 Electrolux Canada Corporation
 5855 Terry Fox Way, Mississauga, ON L5V 3E4
 1-866-738-1640



Kelvinator
 250 Bobby Jones Expressway | Augusta, GA 30907
 Customer Service: (706) 651-1751 | (866) 738-1640
 Parts Department: (800) 599-7569
 www.kelvinator.com

MODELS

COMMERCIAL FREEZER
 BOTTOM MOUNT REACH-IN

KFS220RGW
KFS221LGW

DIMENSIONS

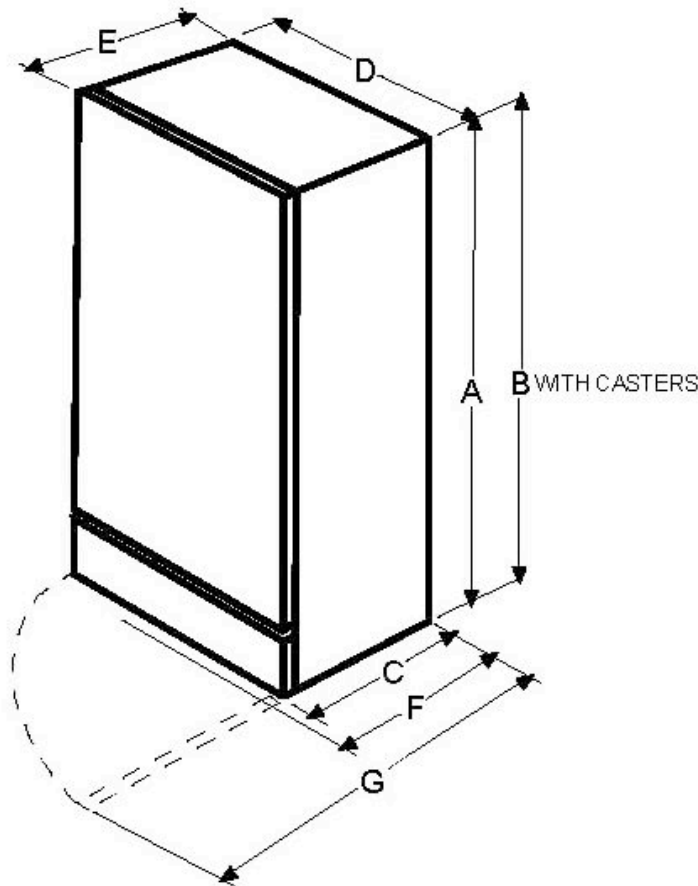

SPECIFICATIONS

MODEL	KCS200GW	KCS130GW
CAPACITY	21.8 CF	21.8 CF
HEIGHT (A)	70"	70"
HEIGHT (B) W/ CASTERS	74-3/4"	74-3/4"
DEPTH (C)	32"	32"
WIDTH (D)	26-1/4"	26-1/4"
DEPTH W/DOOR (E)	28-5/8"	28-5/8"
DEPTH W/HANDLE (F)	30-13/16"	30-13/16"
DEPTH OPEN 90° (G)	59-1/4"	59-1/4"
SHIPPING WEIGHT	273 LBS	273 LBS
UPC (0-12505-)	22521-5	22522-2

ACCESSORIES



Description	Top Shelf	Center Shelf	Trivet	Shelf Support Clips	18" x 26" Pan Rack Kit
Accessory Part #	216386201	216384001	216331801	216605300 (4 Required)	PANRACKKIT Holds 8 sheet pans (not included)

Manufactured by Electrolux Home Products

WARRANTY



USA
 Electrolux Major Appliances, North America
 250 Bobby Jones Expressway, Augusta, GA 30907
 1-866-738-1640 | www.kelvinator.com

CANADA
 Electrolux Canada Corporation
 5855 Terry Fox Way, Mississauga, ON L5V 3E4
 1-866-738-1640

Kelvinator Commercial products are covered by a one year limited warranty. Refer to the Use and Care manual for details.