



Simply Engineered Better

201LT

Undercounter Low Temperature Dishwashing Machine



201LT UNDERCOUNTER

Project _____

Item No. _____

Quantity _____

STANDARD FEATURES

- Pumped drain
- Door safety switch
- Low-water tank heat protection
- Built-in detergent, rinse-aid, and sanitizer dispensing pumps
- Wash pump, 1-Hp motor
- Fill and dump
- Thermostatically controlled wash tank heater maintains water at the required temperature
- Upper & lower interchangeable spray arms
- Top mounted controls
- Stainless steel top and side panels
- Single phase connection
- Stainless steel construction
- 15-3/4" [406mm] door opening accommodates larger wares, including trays!
- Fully automatic wash/rinse cycle processes a rack of wares in 141 seconds ... 21 racks an hour!
- One year parts and labor warranty.

SPECIFIER STATEMENT

Specified unit will be Moyer Diebel Model 201LT undercounter low temperature dishwashing machine. Features include 15-3/4" door opening, standard detergent, rinse-aid and sanitizer dispensing pumps. Wash tank heater maintains required water temperature. 1 year parts and labor warranty.



OPTIONS & ACCESSORIES

- | | |
|---|-------------|
| <input type="checkbox"/> CST- Combination sink/table Machine on right | P/N 403561 |
| <input type="checkbox"/> CST- Combination sink/table Machine on left | P/N 403562 |
| <input type="checkbox"/> Flat bottom dishrack | P/N 101273 |
| <input type="checkbox"/> Peg dishrack | P/N 101285 |
| <input type="checkbox"/> 6" Stand | P/N 0712393 |
| <input type="checkbox"/> 17RS - 17" Stand | P/N 0708757 |

MD032 Printed in U.S.A.

Moyer Diebel - USA

P.O. Box 4183, Winston-Salem, NC 27115 Tel: 336/661-1992 Fax: 336/661-9546 800/228-8350 www.moyerdiebel.com



Dimensions shown in inches and [millimeters]

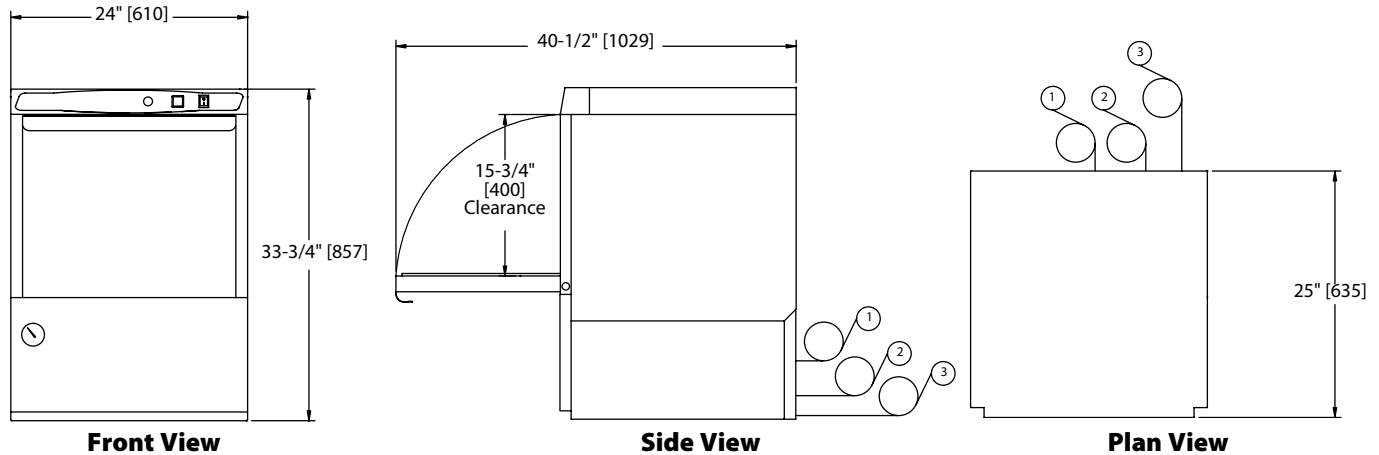

Utilities	
1 Electrical	115/60/1; 12 amp draw; to be fused at 15 amp. 4ft. plug-in cord supplied.
2 Hot Water	140°F Min., 1/2" supply hot water connection 6 ft. long, 1/2" I.D. flexible fill hose with 3/4" hose connector Flow pressure: 25-95 psi (173-656 kPa)
3 Drain Connection	6 ft. long, 5/8" I.D. flexible drain hose Max. drain flow: 15 US gpm

	Uncrated	Crated
Height	33-3/4"	39-1/2"
Width	24"	25"
Depth	25"	25-1/2"
Ship Wt. lbs/kg	178	198

* Front leveling feet provided.

SPECIFICATIONS	
Capacity	
Racks per hr.	21
Motor Horsepower	
Wash	1
Water Consumption	
Per hr. (max. use)	38.4 US gal;
Per rack	1.8 US gal;
Temperatures °F	
Wash (minimum)	140
Rinse (minimum)	140
Heating	
Tank heat, electric (kW)	.75
Time Cycle in Seconds	
Wash	90
Rinse	26
Drain/fill	25
Total	141

Warning: Plumbing and electrical connections should be made by qualified personnel who will observe all the applicable plumbing, sanitary and safety codes.